



Maintenance Engineers Training Course

14th to 17th October 2008 (PL)
20th to 23rd October 2008 (CI)

4 or 8 day Tool Maintenance Course

This course is oriented towards Maintenance Engineers and is designed to give them an in-depth knowledge of production logging and casing inspection tools; how they work, how to maintain and calibrate them, what information we can gain from the logs and how this information is used.

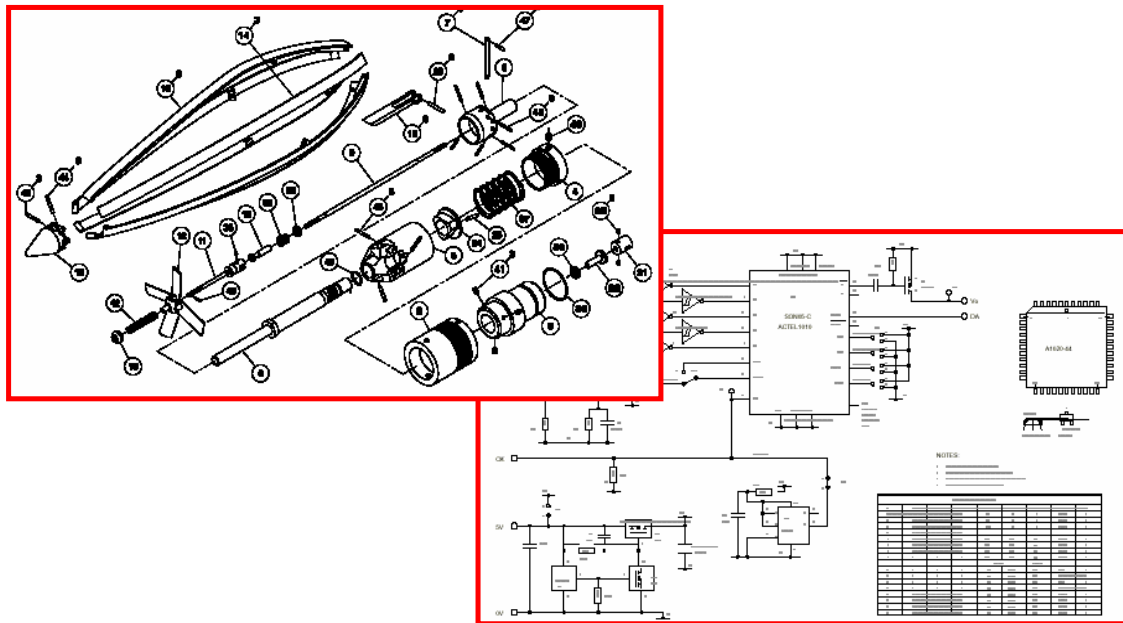

Summary of Topics Covered

- Basic introduction to PL and Casing Inspection and why we use the tools.
- Most common failure modes for various tools.
- Reasons for implementing a preventative maintenance programme.
- Hardware and software requirements for setting up a maintenance laboratory.
- Introduction to tool software – sufficient to check that the tools are working properly.
- Theory – troubleshooting and tool maintenance of individual tools.
- Practical – troubleshooting and tool maintenance of individual tools.